

Test Adapter_N(F) to SMA(F) : 10 GHz (Part #:AD07F06FS1)



Test Adapter_N(F) to SMA(F) : 10 GHz

<Material>

- * Body : Brass (Nickel plated)
- * Contact : BeCu (Gold plated)

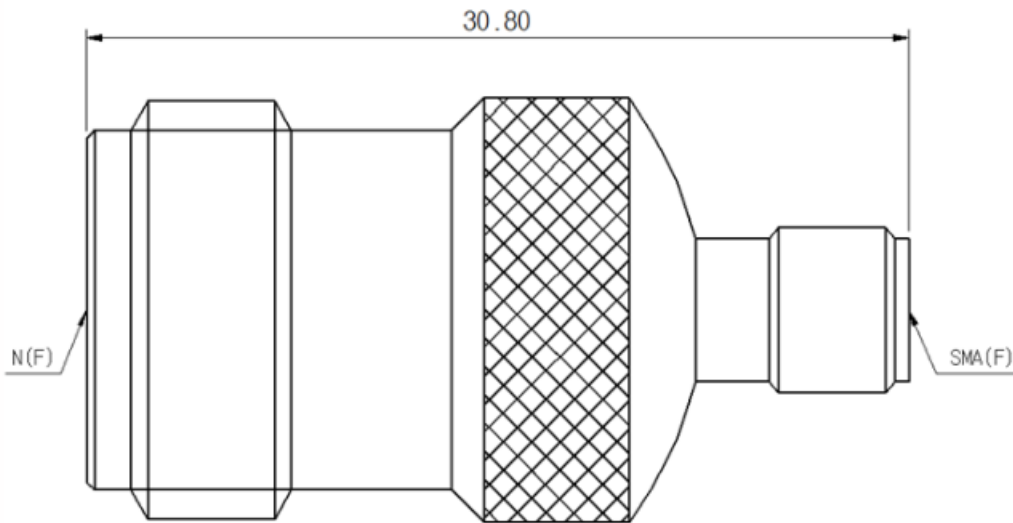

<Test Result>

- * Frequency : 10 MHz to 10 GHz

