

*Withwave's Board Edge SMA is* connectors are specially designed for high frequency substrates to minimize electromagnetic transition effects from coaxial to Microstrip/CPW structure. We solve your performance and cost problems.



### ■ Features

- DC to 26.5 GHz
- Board Clearance : 0.6, 0.8, 1.0, 1.1, 1.2, 1.5, 1.6, 1.7, 2.1, 2.3 & 3.6 mm
- Easy Installation on designed substrate

### ■ Application

- RFIC Chip set evaluation board
- High data rate ASIC and SoC evaluation module test
- Substrate Characterization

### ■ Design Assistance

- 3D Model for Mechanical Layout (STEP file)
- **ANSYS HFSS models** (version 17.0 or newer) for 3D EM(Electromagnetic) Simulation

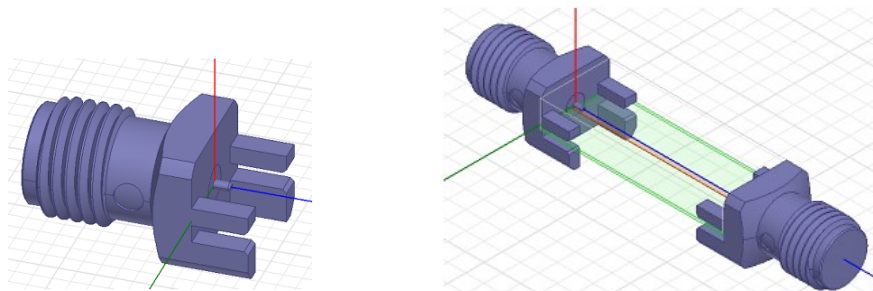

### ■ Specification

Scope	Items	Specification
Electrical	Freq. range	DC to 26.5 GHz
	Impedance	50 Ohm
	VSWR(Max)	1.20 : 1 (18 GHz) 1.30 : 1 (26.5 GHz)
Material	Connector type	SMA
	Body	Brass (gold plated)
	Contact	BeCu (gold plated)
	Operating Temperature	-40~+125°C

\* RoHS Compliant

### ■ Ordering Information

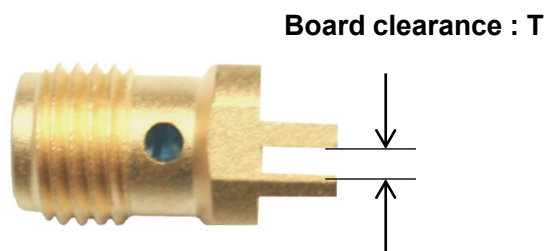

Board Clearance (T : mm)	Part No.
0.6	SM06FS006
0.8	SM06FS007
1.0	SM06FS008
1.1	SM06FS009
1.2	SM06FS010
1.5	SM06FS011
1.6	SM06FS012
1.7	SM06FS013
2.1	SM06FS014
2.3	SM06FS015
2.8	SM06FS016
2.9	SM06FS029
3.6	SM06FS017

### ■ Measurement data

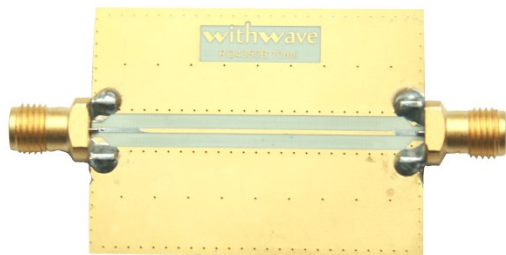

- Frequency : 10 MHz to 26.5 GHz
- Connector : Board Edge SMA (SM06FS007)
- Substrate : RO4350B (10 mil)
- Trace length : 40 mm (microstrip)

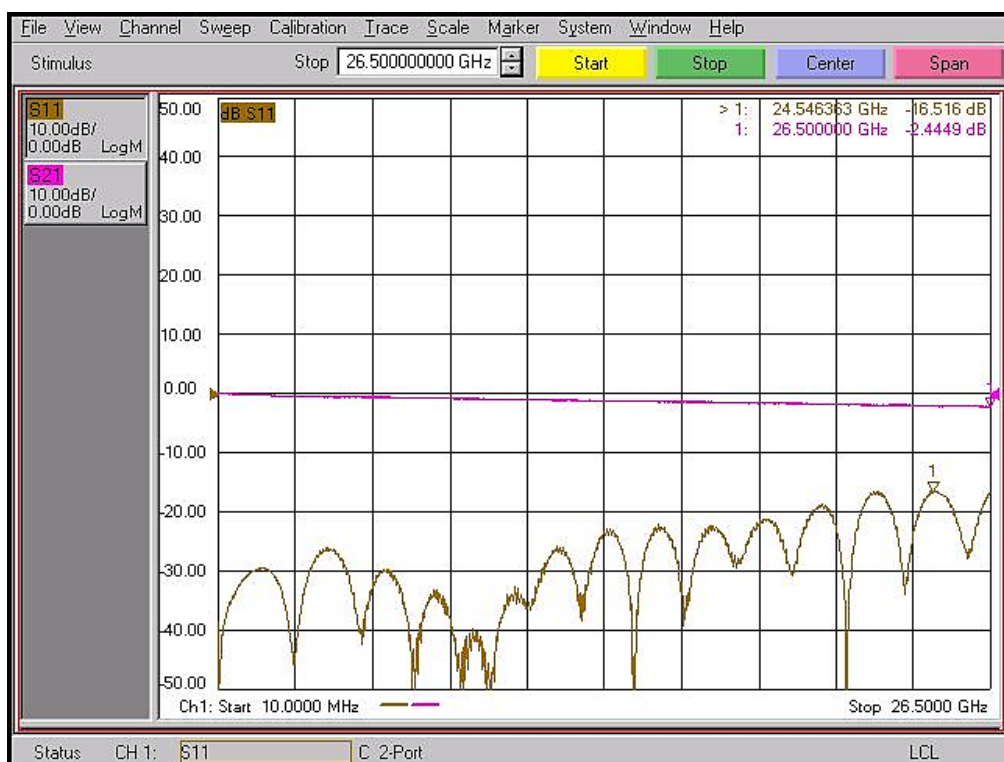

### ■ Drawing

Board Clearance (T : mm)	Part No.
0.6	SM06FS006
0.8	SM06FS007

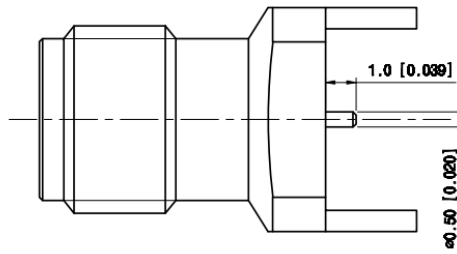
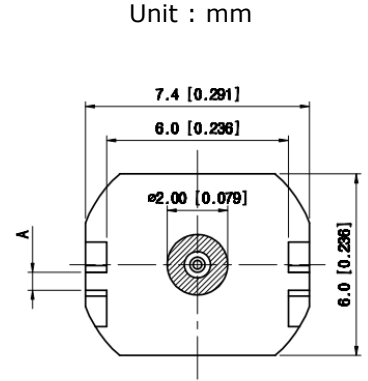
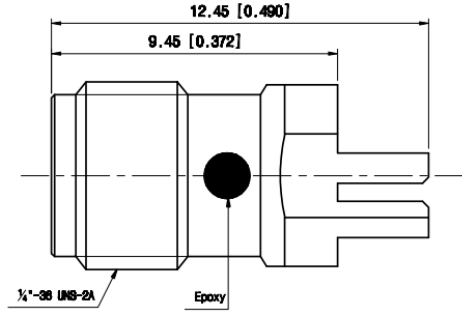

Board Clearance (T : mm)	Part No.
1.0	SM06FS008
1.1	SM06FS009
1.2	SM06FS010
1.5	SM06FS011
1.6	SM06FS012
1.7	SM06FS013
2.1	SM06FS014
2.3	SM06FS015

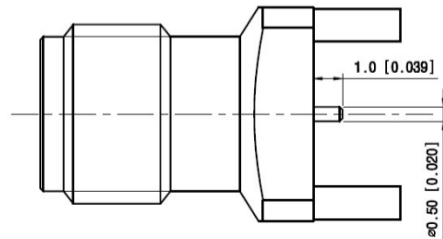
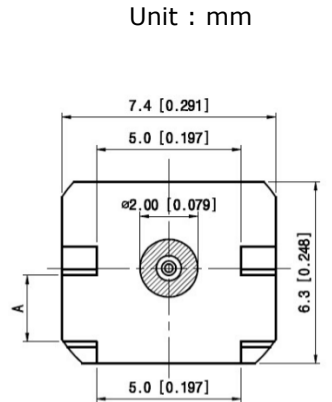
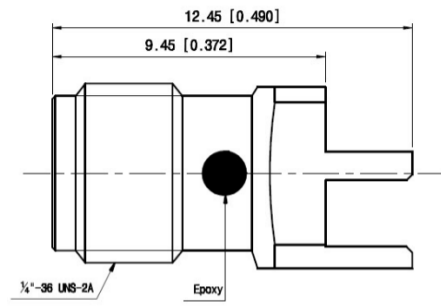

### ■ Drawing

Unit : mm [inch]

Board Clearance (T : mm)	Part No.
2.8	SM06FS016
3.6	SM06FS017

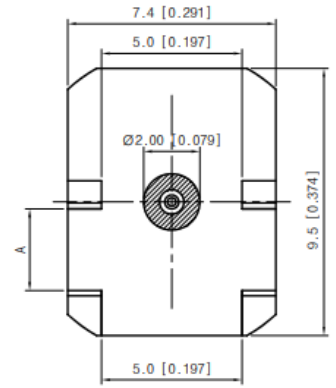
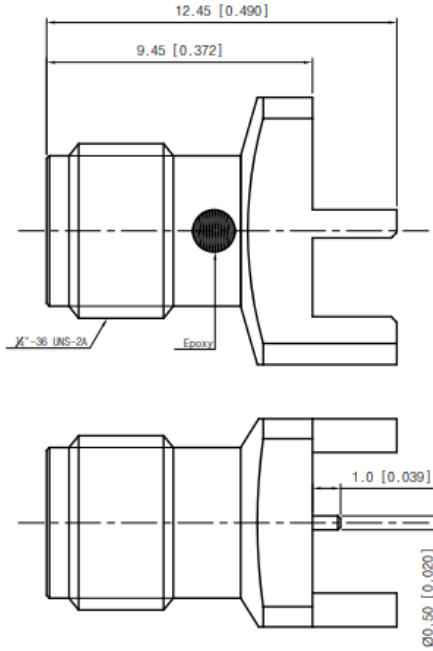

Board Clearance (T : mm)	Part No.
3.6	SM06FS017

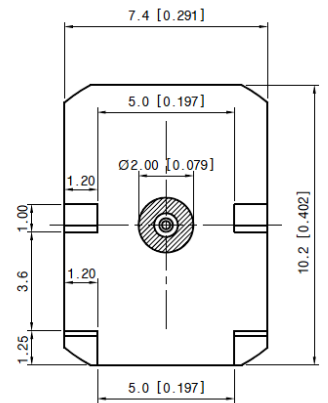
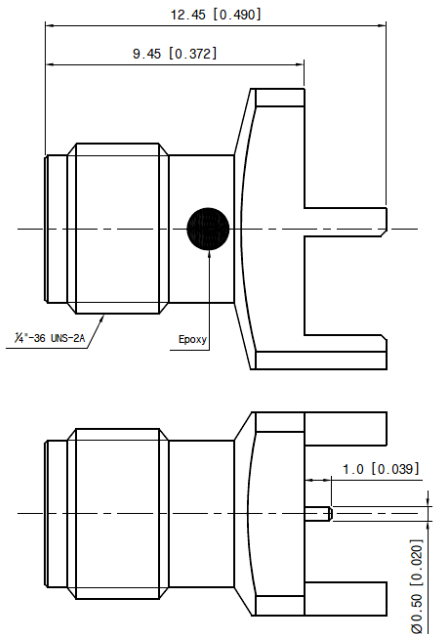

### ■ Installation Procedure

#### STEP 1 :

Insert Board Edge SMA connector at the edge position of substrate.

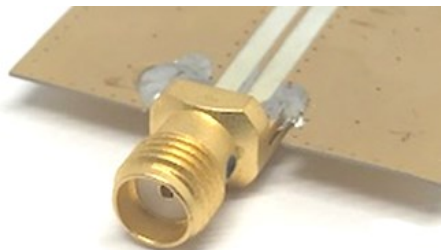

#### STEP 2 :

Make sure contact pin is aligned with the center of the signal trace. and, solder contact pin on the signal trace and two legs on the ground plane while ensuring the connector is held in the correct position.

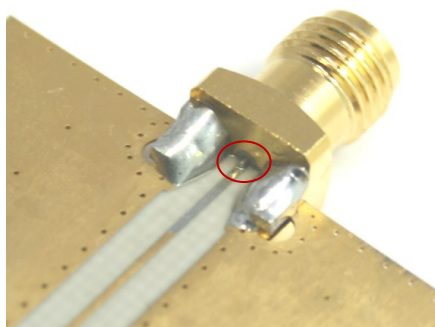

#### STEP 3 :

Solder two legs and connector body on the back side of substrate (ground plane) to improve RF performance. Remove any excess solder and clean all flux and other residues from trace area.

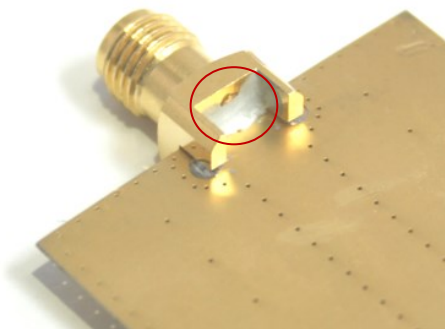

### ■ Recommended Patten

#### RO4003C 8 mil Microstrip type

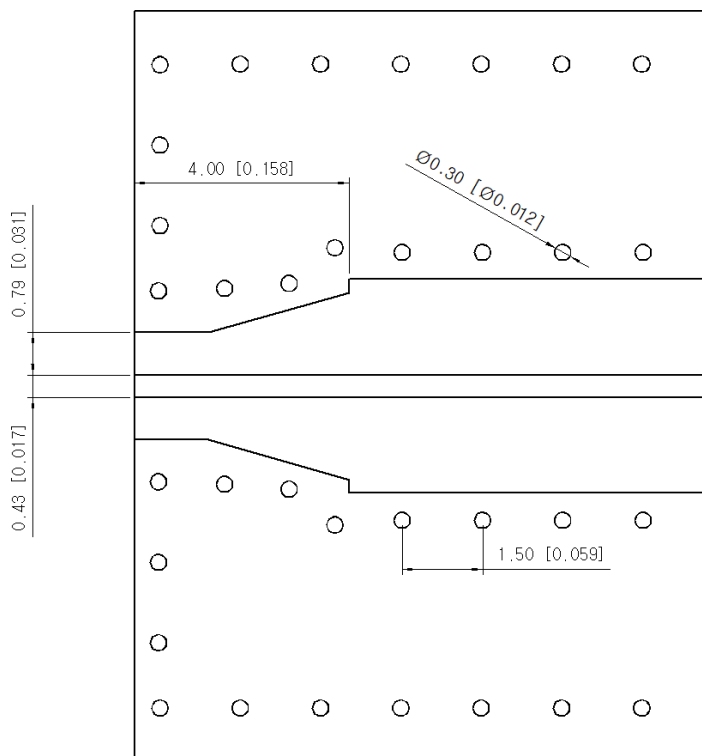

#### RO4003C 12 mil Microstrip type

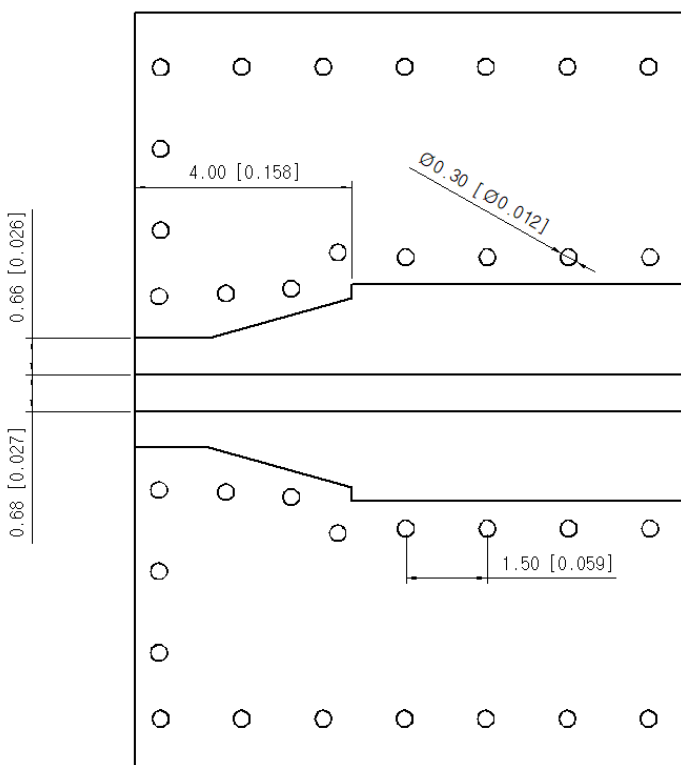

### ■ Recommended Patten

#### **RO4350B 10 mil Microstrip type**

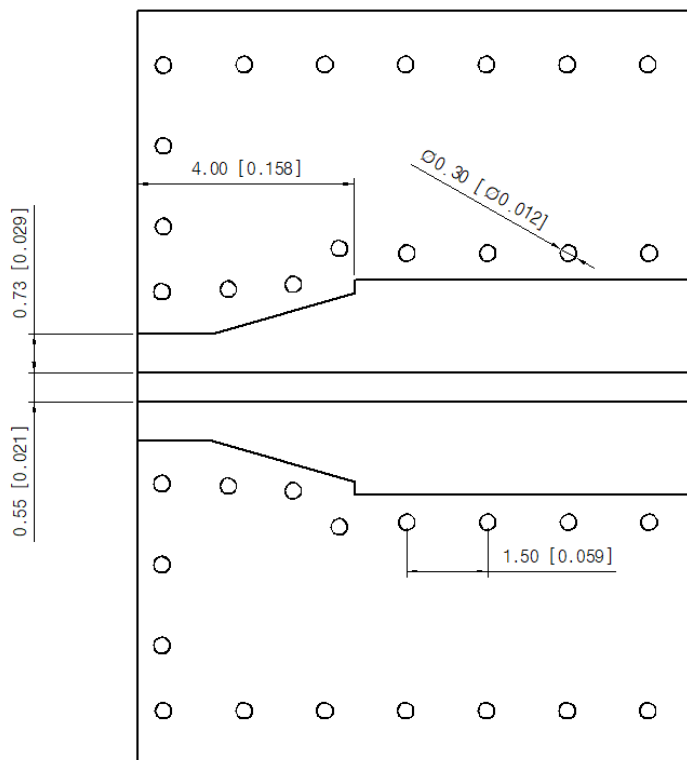

#### **Du5880 5 mil Microstrip type**

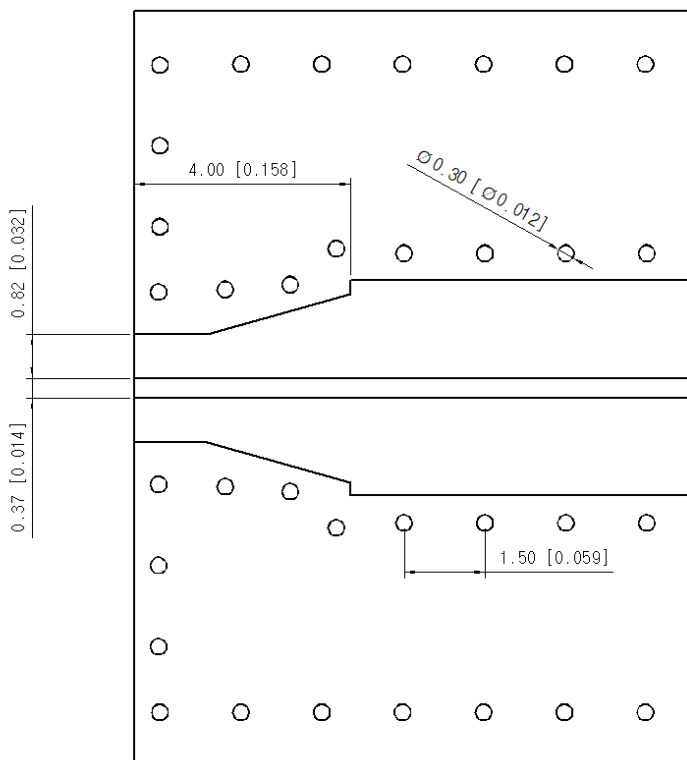



### ■ Recommended Patten

## Du5880 10 mil Microstrip type

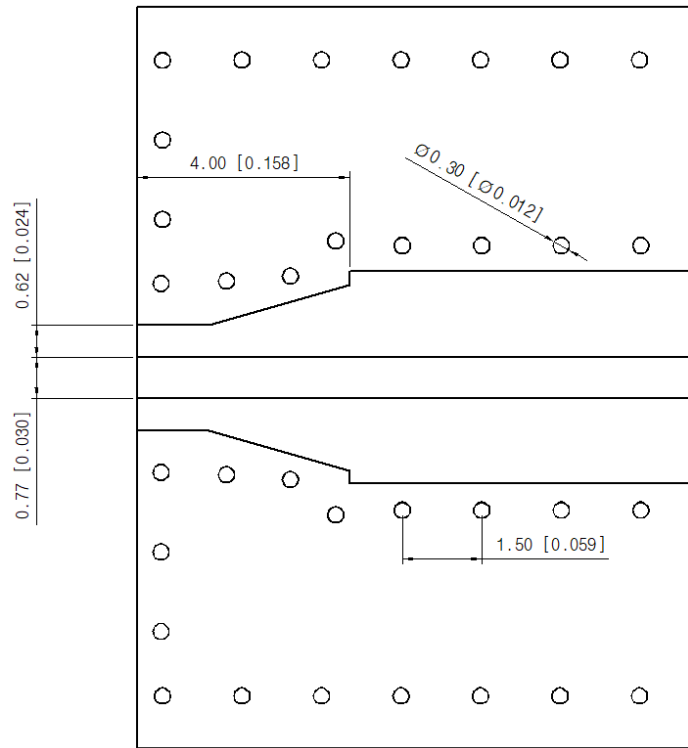

### ■ Revision History

Revision	Date	Changes
Ver 1.2	2018-07-12	Add part number of Board Clearance 3.6 mm (SM06FS017)
Ver.1.3	2018-07-23	Add drawing of Board Clearance 3.6 mm(SM06FS017)
Ver 1.4	2020-08-07	Add Recommended PCB Patterns (Microstrip type) and Installation procedure
Ver 1.5	2023-11-01	Add part number of Board Clearance 2.8 mm(SM06FS016) Add part number of Board Clearance 2.9 mm(SM06FS029)